

Technical report 10-037

# **Optimization of transformer loading based on hot-spot temperature using a predictive health model\***

G. Bajracharya, T. Koltunowicz, R.R. Negenborn, D. Djairam,  
B. De Schutter, and J.J. Smit

*If you want to cite this report, please use the following reference instead:*

G. Bajracharya, T. Koltunowicz, R.R. Negenborn, D. Djairam, B. De Schutter, and J.J. Smit, "Optimization of transformer loading based on hot-spot temperature using a predictive health model," *Proceedings of the 2010 International Conference on Condition Monitoring and Diagnosis (CMD 2010)*, Tokyo, Japan, pp. 914–917, Sept. 2010.

Delft Center for Systems and Control  
Delft University of Technology  
Mekelweg 2, 2628 CD Delft  
The Netherlands  
phone: +31-15-278.24.73 (secretary)  
URL: <https://www.dcsc.tudelft.nl>

---

\*This report can also be downloaded via [https://pub.deschutter.info/abs/10\\_037.html](https://pub.deschutter.info/abs/10_037.html)

# Optimization of Transformer Loading Based on Hot-Spot Temperature using a Predictive Health Model

G. Bajracharya<sup>1\*</sup>, T. Koltunowicz<sup>1</sup>, R. R. Negenborn<sup>2</sup>, D. Djairam<sup>1</sup>, B. De Schutter<sup>2</sup> and J. J. Smit<sup>1</sup>

<sup>1</sup> Dept. of High-Voltage Components and Power Systems, Delft University of Technology, The Netherlands

<sup>2</sup> Delft Center for Systems and Control, Delft University of Technology, The Netherlands

\*E-mail: g.bajracharya@tudelft.nl

**Abstract**—In the future grid, power equipment will need to work with distributed generation, deregulation, and accelerated aging. To this end, a model-based framework for the optimization of usage of power equipment is proposed. The framework uses a predictive health model of the equipment in order to optimize the usage of the equipment. In particular, the predictive health model predicts the hot-spot temperature of the transformers in a network over a future time window based on the expected loading. The allowed loading limits of the transformers are based on the hot-spot temperature. Therefore, the optimal loading of the transformers is maintained by performing an optimal power flow (OPF) computation of the network that takes into account hot-spot temperature dynamics. The optimization determines values for the tap position of the transformers and the active and reactive power of generators in the network. Moreover, shedding of the loads in the network is considered when the aforementioned options are not sufficient to control the loading of the transformers. A case study using the IEEE 14-bus benchmark system is presented. The shedding of the loads is minimized by using this technique.

**Index Terms**—transformer loading; predictive health model; hot-spot temperature; thermal loading; optimal power flow

## I. INTRODUCTION

The electrical power system has been changing drastically in recent years, especially due to the introduction of deregulation of the power industry in most parts of the world. Not only the structure of electrical grids, but also the ways of financing generation, transmission, and distribution have changed from the traditional state-owned utility approach into an investment-oriented approach of power companies [1, 2]. Moreover, a significant portion of the electrical infrastructure will be reaching the end of its operational age within the coming few decades. There is a need for maximum utilization of equipment without degrading the reliability of the system. In order to optimize the operation and maintenance of power system equipment, while assuring a predefined level of reliability, a model describing the evolution of its health state, has to be incorporated into the asset management [3].

In [3], a framework was proposed for modeling the health state of power system equipment. The framework has been

This research is supported by the SenterNovem Sinergie project EOSLT04034, the BSIK project “Next Generation Infrastructures (NGI)”, the Delft Research Center Next Generation Infrastructures, and the European STREP project “Hierarchical and distributed model predictive control (HD-MPC)”.

used in optimizing the loading of a single transformer using temperature predictions in [4]. The hot-spot temperature is used to determine the loading limits. This hot-spot temperature can be predicted using the load of the transformer [5].

In this paper, loading of several transformers in a network is considered. The optimal limits of loading depend on the hot-spot temperature of the transformers. Therefore the optimal loading of the transformers is determined by performing an optimal power flow (OPF) computation of the network that takes into account the hot-spot temperature dynamics.

The outline of this paper is as follows. In Section II, the predicted health model for the prediction of the hot-spot temperature is presented. Section III proposes the control of transformers in a network based on the hot-spot temperature prediction. A case study of the IEEE 14 bus network is presented in Section IV. Conclusions and future work are included in Section V.

## II. PREDICTIVE HEALTH MODEL

Our framework consists of a predictive health model that can be used to predict the effects of different maintenance actions and usage patterns [3]. The predictions can then be used for the optimization of maintenance actions and the equipment usage.

The predictive health model in the framework includes a dynamic stress model. As equipment ages, various stresses, such as electrical, thermal, mechanical, and environmental stresses, weaken the strength of the equipment. As the cumulative stresses increase over time, the reliability and the remaining life of the equipment decrease. The cumulative stresses of the equipment are affected by the usage patterns (e.g., the loading) and the maintenance actions (e.g., the replacement of parts) performed on the equipment. The health state of the equipment is represented by the cumulative stresses. The dynamics of the cumulative stresses can be described using a dynamic stress model given by:

$$\hat{\mathbf{x}}(k+1) = \mathbf{f}(\hat{\mathbf{x}}(k), \mathbf{u}(k)), \quad (1)$$

where at discrete time step  $k$ , with  $\mathbf{u}(k) = [\mathbf{u}_a^T(k) \ \mathbf{u}_d^T(k)]^T$ , the function  $\mathbf{f}$  describes the future cumulative stresses  $\hat{\mathbf{x}}(k+1)$  based on the usage of the equipment  $\mathbf{u}_d(k)$ , the maintenance actions  $\mathbf{u}_a(k)$ , and the current cumulative stresses  $\hat{\mathbf{x}}(k)$ .

### A. Predictive health model of a transformer

The temperature rise due to the loading of a transformer degrades the paper insulation of the transformer. This degradation process reduces the dielectric and mechanical strength of the insulation paper and hence reduces its life time. In order to determine the allowed loading limit of a transformer, the hot-spot temperature is considered. This temperature is used for determining the level of the paper degradation. The hot-spot temperature can be predicted with a thermal model.

The thermal model of a transformer consists of the top-oil model and a hot-spot model [5]. The differential equations of the top-oil model and the hot-spot model are discretized by using the forward Euler approximation. The discretized top-oil model is then given by:

$$\begin{aligned} & \frac{1 + R(u_I(k))^2}{1 + R} (\mu_{pu}(k))^n \Delta\theta_{oil, rated} \\ &= (\mu_{pu}(k))^n \tau_{oil, rated} \frac{x_{\theta, oil}(k+1) - x_{\theta, oil}(k)}{h} \\ &+ \frac{(x_{\theta, oil}(k) - u_{\theta, amb}(k))^{n+1}}{(\Delta\theta_{oil, rated})^n}, \end{aligned} \quad (2)$$

where  $x_{\theta, oil}$  is the top-oil temperature,  $u_{\theta, amb}$  is the ambient temperature,  $u_I$  is the load factor,  $R$  is the ratio of load losses at the rated current and no-load losses,  $\Delta\theta_{oil, rated}$  is the top-oil temperature rise over the ambient temperature at the rated load,  $\mu_{pu}(k)$  is the variable oil viscosity in per unit (pu),  $\tau_{oil, rated}$  is the rated top-oil time constant,  $n$  is a constant that depends on the type of cooling, and  $h$  is the time step for discretization [4]. The change in viscosity of oil at the top-oil temperature  $\mu_{pu}(k)$  is given by [5]:

$$\mu_{pu}(k) = \frac{\exp\left(2797.3/(x_{\theta, oil}(k) + 273)\right)}{\exp\left(2797.3/(\theta_{oil, rated} + 273)\right)}.$$

The discretized hot-spot model is as follows:

$$\begin{aligned} & (u_I(k))^2 P_{cu, pu}(k) (\mu_{pu}(k))^n \Delta\theta_{hs, rated} \\ &= (\mu_{pu}(k))^n \tau_{wdg, rated} \frac{x_{\theta, hs}(k+1) - x_{\theta, hs}(k)}{h} \\ &+ \frac{(x_{\theta, hs}(k) - x_{\theta, oil}(k))^{n+1}}{(\Delta\theta_{hs, rated})^n} \end{aligned} \quad (3)$$

where  $x_{\theta, hs}$  is the hot-spot temperature,  $\Delta\theta_{hs, rated}$  is the rated hot-spot temperature rise over the top-oil temperature,  $P_{cu, pu}(k)$  are the variable load losses in pu, and  $\tau_{wdg, rated}$  is the rated hot-spot time constant [4]. The variable load losses  $P_{cu, pu}(k)$  are given by [5]:

$$P_{cu, pu}(k) = P_{cu, dc, pu} \frac{235 + x_{\theta, hs}(k)}{235 + \theta_{hs, rated}} + P_{cu, eddy, pu} \frac{235 + \theta_{hs, rated}}{235 + x_{\theta, hs}(k)},$$

where  $P_{cu, dc, pu}$  are the DC losses in pu,  $P_{cu, eddy, pu}$  are the eddy current losses in pu, and  $\theta_{hs, rated}$  is the rated hot-spot temperature.

Together the top-oil model (2) and the hot-spot model (3) form the dynamic stress model (1) of the model-based optimization framework.

### III. CONTROL OF TRANSFORMER LOADING IN A NETWORK

Typically, the loading limits of transformers in a network are fixed at constant levels by the manufacturers and/or utilities. However, the maximum allowable loading of a transformer mainly depends on the thermal limits of the transformer. The hot-spot temperature of the transformer can be used to determine the maximum allowable loading. In this paper, normal life expectancy loading defined in IEEE C57.91 [6] is considered. The maximum hot-spot temperature allowed for this type of loading is 120 °C.

The predictive health model described in the previous section is used to predict the hot-spot temperature  $x_{\theta, hs}$ . The predicted hot-spot temperature has to be maintained below the allowed limit by controlling the loading of the transformers  $u_I$ . The loading of the transformers  $u_I$  can be controlled by controlling the active and reactive power of generators and loads. The loading  $u_I$  can also be controlled by controlling network parameters, such as transformer tap settings. Active and reactive power generation, load control (shedding or transfer of loads), and the tap position of transformers are therefore considered as control inputs.

#### A. Optimal power flow of the network with the dynamics of the hot-spot and top-oil temperatures

In order to determine the optimal control inputs, an OPF of the network is calculated. The dynamics of the hot-spot temperature (2) and the top-oil temperature (3) are considered in this OPF.

The dynamic OPF problem is formulated as follows:

$$\min_{\tilde{\mathbf{u}}(k)} J_{total}(\tilde{\mathbf{x}}(k+1), \tilde{\mathbf{z}}(k), \tilde{\mathbf{u}}(k)) \quad (4)$$

subject to:

$$\begin{aligned} \tilde{\mathbf{x}}(k+1) &= \mathbf{f}(\tilde{\mathbf{x}}(k), \tilde{\mathbf{z}}(k), \tilde{\mathbf{u}}(k)) \\ \mathbf{g}(\tilde{\mathbf{x}}(k), \tilde{\mathbf{z}}(k), \tilde{\mathbf{u}}(k)) &= 0 \\ \mathbf{g}(\tilde{\mathbf{x}}(k), \tilde{\mathbf{z}}(k), \tilde{\mathbf{u}}(k)) &\leq 0 \end{aligned}$$

where the tilde over a variable represents a vector with the values of this variable over a prediction horizon of  $N$  steps, e.g.,

$$\tilde{\mathbf{u}}(k) = [\mathbf{u}^T(k), \dots, \mathbf{u}^T(k+N-1)]^T.$$

The OPF is considered for a prediction horizon of  $N$  steps in the future. The three sets of variables considered in the OPF [2] are:

- The algebraic state vector  $\mathbf{z}(k)$  includes the variables for which no dynamics are considered,

$$\mathbf{z}(k) = [z_{\theta}^{i_1}(k), z_v^{i_1}(k), \dots, z_{\theta}^{i_{b,n}}(k), z_v^{i_{b,n}}(k)]^T, \quad (5)$$

with  $\mathcal{S}_{bus} = \{i_1, \dots, i_{b,n}\}$  the set of indices of buses in the network, where  $z_{\theta}^i(k)$  and  $z_v^i(k)$  are the angle and the voltage magnitude of bus  $i$ , respectively. The dynamics for the variables are neglected because it is too fast compare to the dynamics of the hot-spot temperature and the top-oil temperature.

- The dynamic state vector  $\mathbf{x}(k)$  includes the variables for which dynamics are defined,

$$\mathbf{x}(k) = [x_{\theta, \text{oil}}^{j_1}(k), x_{\theta, \text{hs}}^{j_1}(k), \dots, x_{\theta, \text{oil}}^{j_{t,n}}(k), x_{\theta, \text{hs}}^{j_{t,n}}(k)]^T \quad (6)$$

with  $\mathcal{S}_{\text{tr}} = \{j_1, \dots, j_{t,n}\}$  the set of indices of transformers in the network, where  $x_{\theta, \text{oil}}^j(k)$  and  $x_{\theta, \text{hs}}^j(k)$  are the top-oil temperature and the hot-spot temperature of transformer  $j$ , respectively.

- The control vector  $\mathbf{u}(k)$  consists of the control inputs of the network,

$$\mathbf{u}(k) = [u_{\text{P,gen}}^{i_1}(k), u_{\text{Q,gen}}^{i_1}(k), u_{\text{tap}}^{j_1}(k), u_{\text{shed}}^{k_1}(k), \dots, u_{\text{P,gen}}^{i_{g,n}}(k), u_{\text{Q,gen}}^{i_{g,n}}(k), u_{\text{tap}}^{j_{t,n}}(k), u_{\text{shed}}^{k_{s,n}}(k)]^T, \quad (7)$$

with  $\mathcal{S}_{\text{gen}} = \{i_1, \dots, i_{g,n}\}$  the set of indices of generators in the network,  $\mathcal{S}_{\text{tr}} = \{j_1, \dots, j_{t,n}\}$  the set of indices of transformers in the network, and  $\mathcal{S}_{\text{load}} = \{m_1, \dots, m_{s,n}\}$  the set of indices of loads in the network, where  $u_{\text{P,gen}}^i(k)$  and  $u_{\text{Q,gen}}^i(k)$  are the active and the reactive power generation at bus  $i$ ,  $u_{\text{tap}}^j(k)$  is the tap position of transformer  $j$ , and  $u_{\text{shed}}^m(k)$  is the shedding of the load at bus  $m$ . Shedding of the active and the reactive load is given by:

$$P_{\text{load,actual}}^m(k) = (1 - u_{\text{shed}}^m(k)) P_{\text{load,demand}}^m(k)$$

$$Q_{\text{load,actual}}^m(k) = (1 - u_{\text{shed}}^m(k)) Q_{\text{load,demand}}^m(k)$$

for  $0 \leq u_{\text{shed}}^m(k) \leq 1$ , where  $P_{\text{load,demand}}^m(k)$  and  $Q_{\text{load,demand}}^m(k)$  are the real power and the reactive power demand at bus  $m$ , respectively, and where  $P_{\text{load,actual}}^m(k)$  and  $Q_{\text{load,actual}}^m(k)$  are the real power and the reactive power delivered at bus  $m$ , respectively.

Nodal power balances between the nodes in the network  $\mathbf{g}$  are considered as constraints for the optimization. The predictive health model  $\mathbf{f}$ , which describes the dynamics of the hot-spot temperature (2) and the top oil temperature (3), are constraints of the optimization problem. The branch flow limits are given by  $\mathbf{h}$ . For transformers, the maximum hot-spot temperature limit is given by:

$$x_{\theta, \text{hs}}^j(k+1) \leq x_{\theta, \text{hs}}^{\text{max}} \quad (8)$$

Allowable voltage magnitudes in the network are taken into account by the variable limits. Maximum and minimum generation capacities of generators are also considered in the variable limits.

The total cost function over the prediction horizon  $N$  is given by:

$$J_{\text{total}}(\tilde{\mathbf{x}}(k+1), \tilde{\mathbf{z}}(k), \tilde{\mathbf{u}}(k)) = \sum_{l=0}^N \left[ \sum_{i \in \mathcal{S}_{\text{gen}}} J_{\text{gen}}(u_{\text{P,gen}}^i(k+l), u_{\text{Q,gen}}^i(k+l)) + \sum_{j \in \mathcal{S}_{\text{tr}}} J_{\text{tap}}(u_{\text{tap}}^j(k+l)) + \sum_{m \in \mathcal{S}_{\text{load}}} J_{\text{shed}}(u_{\text{shed}}^m(k+l)) \right] \quad (9)$$

where  $J_{\text{gen}}$ ,  $J_{\text{tap}}$ , and  $J_{\text{shed}}$  give the cost of generation, the cost of tap and the cost of load shedding, respectively.

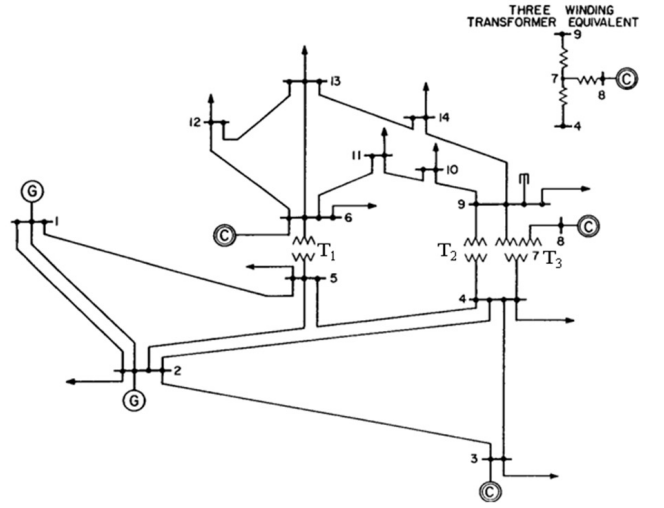

Fig. 1. IEEE 14 bus network which consists of 3 transformers [7].

## IV. CASE STUDY

### A. IEEE 14 bus network

The IEEE 14 bus network [7], illustrated in Figure 1, is used as case study. The network includes transmission and distribution systems. The network consists of three transformers  $T_1$ ,  $T_2$ , and  $T_3$ . Three generators are considered at buses 1, 2, and 3. Two reactive power compensators are assumed to be controllable. Shedding is allowed at buses 6, 9, 10, 11, 12, 13, and 14. Data of the network parameters and the limits of the active and the reactive power generation are given in [7]. The allowable limit of voltage variation in the buses is considered to be  $\pm 6\%$ .

The cost of generation  $J_{\text{gen}}$  is given by:

$$J_{\text{gen}}(u_{\text{P,gen}}^i(k), u_{\text{Q,gen}}^i(k)) = C_1^i u_{\text{P,gen}}^i(k) + C_2^i (u_{\text{P,gen}}^i(k))^2,$$

where  $C_1^1 = 20$ ,  $C_1^2 = 20$ ,  $C_1^3 = 20$ ,  $C_1^6 = 40$ ,  $C_1^8 = 40$ ,  $C_2^1 = 0.043$ ,  $C_2^2 = 0.25$ ,  $C_2^3 = 0.01$ ,  $C_2^6 = 0.01$ , and  $C_2^8 = 0.01$ .

The cost of tap changes is given by:

$$J_{\text{tap}}(u_{\text{tap}}^j(k)) = (u_{\text{tap}}^j(k))^2.$$

The cost of shedding is chosen to be higher than the cost of generation to avoid shedding as much as possible. The cost of shedding  $J_{\text{shed}}$  is given by:

$$J_{\text{shed}}(u_{\text{shed}}^m(k)) = D_1 u_{\text{shed}}^m(k) P_{\text{load}}^m(k) + D_2 (u_{\text{shed}}^m(k) P_{\text{load}}^m(k))^2,$$

where  $D_1 = 80$  and  $D_2 = 0.5$ .

The nominal ratings of transformers  $T_1$ ,  $T_2$ , and  $T_3$  are considered to be 50 MVA, 17 MVA, and 40 MVA respectively. The thermal parameters of transformers are taken from the medium and large power transformers (ONAN) given in [8]. For the simulation purposes, an ambient temperature  $u_{\theta, \text{amb}}(k)$  of  $25^\circ\text{C}$  is considered.

In order to emphasize the loading of transformers, the power flow in the network is not considered to be constrained by the loading capacities of the transmission and distribution

lines. In other words, the loading capacities of the transformers are considered as the bottlenecks in the network.

### B. Loading considering the hot-spot temperature

The optimal power flow computation for a load profile is calculated. A step time  $h$  of 1 minute is considered. A prediction horizon  $N$  of 5 steps is chosen. Figure 2 gives the load demands (in dotted lines) and the actual loads (in solid lines) at the distribution buses. The hot-spot temperature and the top-oil temperature of the transformer are presented in Figure 3.

As illustrated in Figure 3, the hot-spot temperature of transformer  $T_2$   $x_{\theta,hs}^2$  reaches the maximum limit of  $120^\circ\text{C}$  at  $k = 169$ . The loading of transformer  $T_2$  is maintained such that its hot-spot temperature stays at the limit. At this point, loads are not shed. At  $k = 207$ , the hot-spot temperature of transformer  $T_1$   $x_{\theta,hs}^1$  also reaches the limit. As the hot-spot temperature of transformer  $T_1$  and  $T_2$  reaches the limit, the power flow cannot be controlled with the generation control and the tap control. As a result, the shedding of load at bus 9 starts. As seen in Figure 2, the actual load (solid line) is less than the load demand (dotted line) for range of  $k$  between time steps 207 and 252. As the load demands decrease, the hot-spot temperature of transformer  $T_1$   $x_{\theta,hs}^1$  reduces (after  $k = 252$ ) and the shedding is eliminated.

## V. CONCLUSIONS AND FUTURE WORK

A predictive health model for the hot-spot temperature prediction of transformers has been developed. The hot-spot prediction has been used in determining the loading limits of transformers in a network. The loading of the transformers is controlled by changing the active and the reactive power generation and the tap setting of the transformers. The shedding of the load is done when the loading of the transformer cannot be limited by controlling the generation and the tap settings. The hot-spot temperatures of the transformers are maintained below the maximum allowed limit.

The hot-spot temperatures of the transformers will be used for estimating the degradation of the transformers. The degradation of the transformers will be expressed in terms of degree of polymerization of the paper insulation. By considering the degradation, other loading regimes defined in IEEE C57.91 will be included.

## REFERENCES

- [1] J. J. Smit, "Trends in emerging technologies in power systems," in Proceedings of the 2005 International Conference on Future Power Systems, Amsterdam, The Netherlands, pp. 1–7, November 2005.
- [2] R.R. Negenborn, Z. Lukszo, and H. Hellendoorn (Eds.). Intelligent Infrastructures, Springer, Dordrecht, The Netherlands, 2010.
- [3] G. Bajracharya, T. Koltunowicz, R. R. Negenborn, Z. Papp, D. Djairam, and B. De Schutter, J. J. Smit, "Optimization of Maintenance for Power System Equipment Using a Predictive Health Model," in Proceedings of the 2009 IEEE Bucharest PowerTech Conference, Bucharest, Romania, pp. 1–6, July 2009.
- [4] G. Bajracharya, T. Koltunowicz, R. R. Negenborn, Z. Papp, D. Djairam, B. De Schutter, and J. J. Smit, "Optimization of condition-based asset management using predictive health model," in Proceedings of the 16th International Symposium on High Voltage Engineering 2009, Cape Town, South Africa, August 2009.

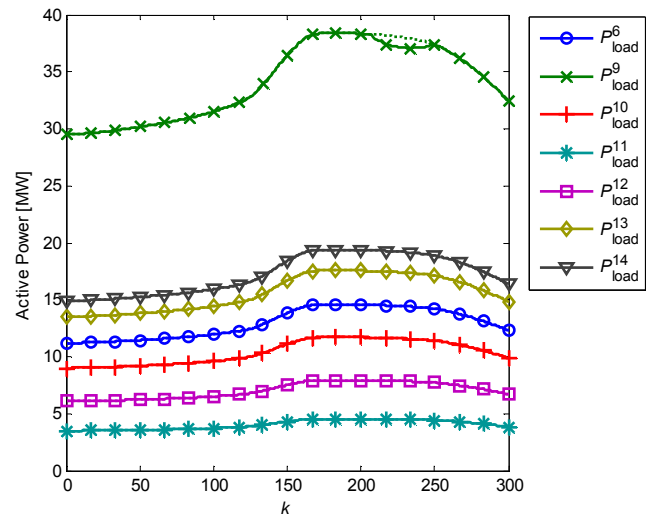

Fig. 2. Demand of the real power (dotted lines) and Actual real power delivered (solid lines) at buses of the distribution system.

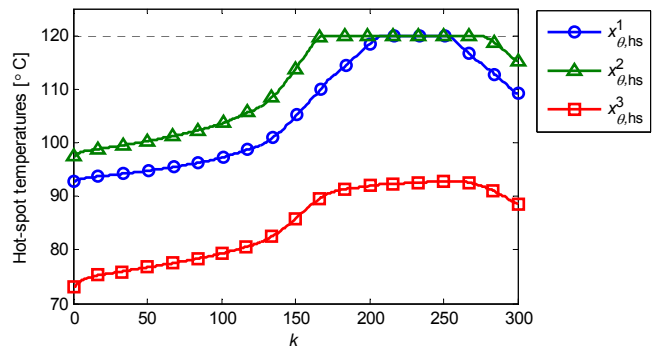

Fig. 3. Hot-spot and top-oil temperatures of transformers  $T_1$ ,  $T_2$ , and  $T_3$ .

- [5] D. Susa, M. Lehtonen, H. Nordman, "Dynamic Thermal Modelling of Power Transformers," IEEE Transactions of Power Delivery, vol. 20, no. 1, pp. 197–204, January 2005.
- [6] IEEE Guide for Loading Mineral-Oil-Immersed Transformers, IEEE Standard C57.91-1995, June 1995.
- [7] IEEE 14 bus power flow test case, URL: [http://www.ee.washington.edu/research/pstca/pf14/pg\\_tca14bus.htm](http://www.ee.washington.edu/research/pstca/pf14/pg_tca14bus.htm).
- [8] Power transformers - Part 7: Loading guide for oil-immersed power transformers, IEC Standard 60076-7-2008, December 2008.