

Distributed Kalman Filter with Embedded Consensus Filters

Reza Olfati-Saber
Dartmouth College
Thayer School of Engineering
Hanover, NH 03755
olfati@dartmouth.edu

Abstract—The problem of distributed Kalman filtering (DKF) for sensor networks is one of the most fundamental distributed estimation problems for scalable sensor fusion. This paper addresses the DKF problem by reducing it to two separate dynamic consensus problems in terms of weighted measurements and inverse-covariance matrices. These to data fusion problems are solved in a distributed way using low-pass and band-pass consensus filters. Consensus filters are distributed algorithms that allow calculation of average-consensus of time-varying signals. The stability properties of consensus filters is discussed in a companion CDC '05 paper [24]. We show that a central Kalman filter for sensor networks can be decomposed into n micro-Kalman filters with inputs that are provided by two types of consensus filters. This network of micro-Kalman filters collectively are capable to provide an estimate of the state of the process (under observation) that is identical to the estimate obtained by a central Kalman filter given that all nodes agree on two central sums. Later, we demonstrate that our consensus filters can approximate these sums and that gives an approximate distributed Kalman filtering algorithm. A detailed account of the computational and communication architecture of the algorithm is provided. Simulation results are presented for a sensor network with 200 nodes and more than 1000 links.

Index Terms—sensor networks, distributed Kalman filter, sensor fusion, consensus filters, dynamic average-consensus, networked embedded systems, random networks

I. INTRODUCTION

Sensor networks and intelligent arrays of micro-sensors have broad range of applications including information gathering and data fusion for modeling an environment, surveillance, active monitoring of forests & agricultural lands, health-care applications, collaborative information processing, and control of smart materials with embedded sensors [7], [13], [16], [4], [1], [9], [5], [19], [15], [3], [33], [22], [8].

The most fundamental distributed estimation problem for sensor networks is to develop a distributed algorithm [14] for *Kalman filtering* [2]. A scheme for approximate distributed Kalman filtering (DKF) was proposed in [30] based on reaching an *average-consensus* [23], [27], [21]. The work in [30] only suggests a scalable scheme to tackle the DKF problem in a special case of full-information and does not contain the sufficient analytical results and distributed algorithms necessary to implement a distributed Kalman filter.

This paper provides the essential distributed algorithms and analytical guarantees necessary to establish: a) The DKF problem can be reduced to two *dynamic consensus* problems

regarding fusion of the measurements and covariance information and b) Solving the two dynamic consensus problems requires appropriate *consensus filters* (i.e. a low-pass filter and a band-pass filter). A detailed discussion of consensus filters that solve dynamic consensus problems and their stability properties is provided in [24], [29]. In particular, the low-pass consensus filter in [24] plays a crucial role in both data fusion problems in part b).

The problem of decentralized Kalman filtering was first solved by Speyer [31]¹ in 1979. It was independently resolved by Rao, Durrant-Whyte, and Sheen in [25]. Both methods require a complete network with all-to-all links. This solution is not scalable for large-scale sensor networks due to its $O(n^2)$ communication complexity (n is the number of sensors/nodes). Thus, decentralized Kalman filtering and distributed Kalman filtering are two separate problems. In the latter one, each node only is allowed to communicate with its neighbors on a graph G that is connected but rather sparse.

Consensus problems [23], [27] and their special cases have been the subject of intensive studies by several researchers [17], [21], [12], [18], [26], [32], [33] in the context of formation control, self-alignment, and flocking [20] in networked dynamic systems.

An in-depth comparison between the distributed Kalman filter introduced here and the existing decentralized sensor fusion algorithms both with and without fusion centers in [34], [28], [6], [11] is the subject of ongoing investigation.

An outline of the paper is as follows: Section II provides some background on the information form of Kalman filter. Section III contains our first main result on decomposition of a Kalman filter into n collaborative micro-Kalman filters with local communication. Consensus filters are described in Section IV. Simulation results for a sensor network with 200 nodes and over 1000 links are presented in Section V. Finally, concluding remarks are made in Section VI.

II. KALMAN FILTER: INFORMATION FORM

Consider a sensor network with n sensors that are interconnected via an overlay network G (e.g. a connected undirected graph as shown in Fig. 1).

¹The original work by Speyer was brought up to the attention of the author by J. Shamma and has partially influenced the choice of the information form of the Kalman filter as well as the notation used in the paper.

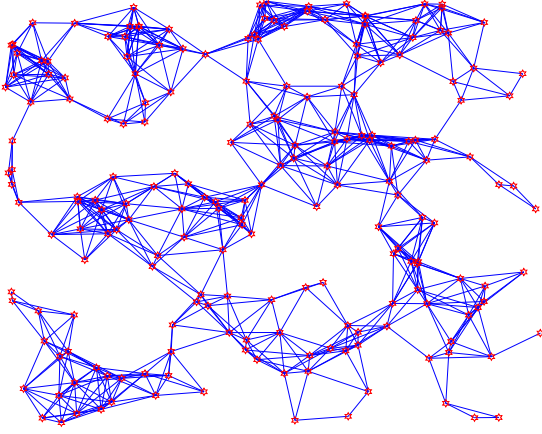

Fig. 1. A sensor network with $n = 200$ nodes and $l = 1074$ links.

This section describes the so-called *information form* of the Kalman filter (IKF) according to [2], [31].

Let us describe the model of a process (e.g. a physical phenomenon or a moving object) and the sensing model of the IKF as follows:

$$\begin{aligned} x_{k+1} &= A_k x_k + B_k w_k; & x_0 \\ z_k &= H_k x_k + v_k \end{aligned} \quad (1)$$

where $z_k \in \mathbb{R}^{np}$ represents the vector of p -dimensional measurements obtained via n sensors, w_k and v_k are white Gaussian noise (WGN), and $x_0 \in \mathbb{R}^m$ denotes the initial state of the process that is a Gaussian random variable. Here is the information regarding the statistics of these variables:

$$E(w_k w_l') = Q_k \delta_{kl}, \quad E(v_k v_l') = R_k \delta_{kl} \quad (2)$$

$$x_0 = \mathcal{N}(\bar{x}_0, P_0). \quad (3)$$

Given the measurements $Z_k = \{z_0, z_1, \dots, z_k\}$, the *state estimates* can be expressed as

$$\hat{x}_k = E(x_k | Z_k), \quad \bar{x}_k = E(x_k | Z_{k-1}), \quad (4)$$

$$P_k = \Sigma_{k|k-1}, \quad M_k = \Sigma_{k|k} \quad (5)$$

where $\Sigma_{k|k-1}$ and $\Sigma_{k|k}$ denote the *state covariance* matrices and their inverses are known as the *information matrices*. Note that $\Sigma_{0|-1} = P_0$. Here are the Kalman filter iterations in the information form:

$$M_k^{-1} = P_k^{-1} + H_k' R_k^{-1} H_k \quad (6)$$

$$K_k = M_k H_k' R_k^{-1} \quad (7)$$

$$\hat{x}_k = \bar{x}_k + K_k (z_k - H_k \bar{x}_k) \quad (8)$$

$$P_{k+1} = A_k M_k A_k' + B_k Q_k B_k' \quad (9)$$

$$\bar{x}_{k+1} = A_k \hat{x}_k \quad (10)$$

III. DISTRIBUTED KALMAN FILTER AND MICRO-KFs

Our first objective is to show how the information form of a central Kalman filter for a sensor network observing a process of dimension m with an np -dimensional measurement vector z_k can be equivalently expressed in *consensus form* using n *micro-Kalman filters* (μ KF) with p -dimensional measurement vectors which are embedded in each sensor so

that the *network of micro-Kalman filters* collectively in a distributed way calculate the same state estimate \hat{x} obtained via application of a central Kalman filter located at a sink node (e.g. for a moving object in a plane $p = 2, m = 4$ and $n \gg 1$).

Let us assume that there are n sensors with $p \times m$ measurement matrices H_i and sensing model:

$$z_i(k) = H_i x(k) + v_i(k)$$

Thus, defining the central measurement, observation noise, and observation matrix as

$$z_c = \text{col}(z_1, z_2, \dots, z_n), \quad (11)$$

$$v_c = \text{col}(v_1, \dots, v_n), \quad (12)$$

$$H_c = [H_1; H_2; \dots; H_n], \quad (13)$$

where H_c is a column block matrix. We get

$$z_c(k) = H_c x(k) + v_c(k) \quad (14)$$

where the subscript ‘‘c’’ means ‘‘central’’. Let

$$R_c = \text{diag}(R_1, R_2, \dots, R_n)$$

denote the covariance of v_c (i.e. we assume v_i 's are uncorrelated). We have²

$$M = (P + H_c' R_c^{-1} H_c)^{-1}$$

and

$$K_c = M H_c' R_c^{-1}.$$

Thus, the *state propagation* equation can be expressed as

$$\hat{x} = \bar{x} + K_c (z_c - H_c \bar{x}) \quad (15)$$

$$= \bar{x} + M (H_c' R_c^{-1} z_c - H_c' R_c^{-1} H_c \bar{x}) \quad (16)$$

Defining the following $m \times m$ average inverse-covariance matrix

$$S = \frac{1}{n} H_c' R_c^{-1} H_c = \frac{1}{n} \sum_{i=1}^n H_i' R_i^{-1} H_i \quad (17)$$

and the m -vector of average measurements

$$y_i = H_i' R_i^{-1} z_i, \quad y = \frac{1}{n} \sum_{i=1}^n y_i, \quad (18)$$

one gets the Kalman state update equation of a μ KF as

$$\hat{x} = \bar{x} + M_\mu (y - S \bar{x}) \quad (19)$$

with a micro-Kalman gain of $M_\mu = nM$, measurement consensus y , and inverse-covariance consensus value of S . The expression for M_μ can be stated as follows:

$$M_\mu = nM = ((nP)^{-1} + S)^{-1}. \quad (20)$$

Denoting $P_\mu = nP$ and $Q_\mu = nQ$, we obtain an update equation of dimension $m \times m$ for a μ KF:

$$P_\mu^+ = A M_\mu A' + B Q_\mu B'. \quad (21)$$

²The iteration numbers are dropped whenever no confusions occur.

Based on the above argument, we have the following decomposition theorem for Kalman filtering in sensor networks:

Theorem 1. (*distributed Kalman filter*) Consider a sensor network with n sensors and topology G that is a connected graph observing a process of dimension m using $p \leq m$ sensor measurements. Assume the nodes of the network solve two consensus problems that allow them to calculate average inverse-covariance S and average measurements y at every iteration k . Then, every node of the network can calculate the state estimate \hat{x} at iteration k using the update equations of its micro-Kalman filter (or μ KF iterations)

$$M_\mu = (P_\mu^{-1} + S)^{-1}, \quad (22)$$

$$\hat{x} = \bar{x} + M_\mu(y - S\bar{x}), \quad (23)$$

$$P_\mu^+ = AM_\mu A' + BQ_\mu B', \quad (24)$$

$$\bar{x}^+ = A\hat{x}. \quad (25)$$

This gives an estimate identical to the one obtained via a central Kalman filter.

Remark 1. The gain M_μ of the micro-Kalman filter has $O(m^2)$ elements, whereas the Kalman gain K of the central Kalman filter has $O(m^2n)$ elements. Thus, the calculations of the central KF require manipulation of large matrices which is not computationally feasible.

Remark 2. We assume all nodes know n or solve a consensus problem to calculate n . This is necessary for calculation of $Q_\mu = nQ$.

Considering that both S and y are *time-varying* quantities, one need to solve two dynamic consensus problems that allow asymptotic tracking of the values of $S(k)$ and $y(k)$ [30]. The nature of these two dynamic consensus problem differ in nature. Consensus in $y(k)$ requires sensor fusion for noisy measurements y_i that can be solved using a newly found *distributed low-pass consensus filter* given in [24]. The consensus regarding the inverse-covariance matrices for calculation of S requires a *band-pass consensus filter* that will be described in the next section. Neither problems can be solved using a high-pass consensus filter alone.

Based on the results in [24], the nodes of a network that uses a consensus filter only reach an ϵ -consensus (for non-static cases). Meaning that all agents reach a state that is in a closed-ball of radius $\epsilon \ll 1$ around the group decision value [24]. This means that practically every node calculates its approximate consensus values \hat{S}_i and \hat{y}_i that all belong to small neighborhoods around S and y , respectively. This gives the following state and covariance update equations for the i th μ KF:

$$M_i = (P_i^{-1} + \hat{S}_i)^{-1}, \quad (26)$$

$$\hat{x} = \bar{x} + M_i(\hat{y}_i - \hat{S}_i\bar{x}), \quad (27)$$

$$P_i^+ = AM_i A' + BQ_\mu B', \quad (28)$$

$$\bar{x}^+ = A\hat{x}, \quad (29)$$

with $P_i = nP$. This is the perturbed version of the exact iterations of the μ KF equation in Theorem 1. The conver-

gence analysis of the collective dynamics of the perturbed μ KF equations is the subject of future research.

IV. CONSENSUS FILTERS

Theorem 1 does not amount to the solution of the DKF problem. So far, we have only managed to show that if two dynamic consensus problems in S and y are solved, then a distributed algorithm for Kalman filtering in sensor networks exists. The crucial part of solving the DKF problem is solving its required dynamic consensus problems which have been addressed in [24] and partially in [29].

We state the distributed algorithms for three consensus filters: a low-pass filter, a high-pass filter, and a resulting band-pass filter. Let us denote the adjacency and Laplacian matrix [10] of G by A and $L = \text{diag}(A\mathbf{1}) - A$, respectively.

- **Low-Pass Consensus Filter (CF_{lp}, [24]):** Let q_i denote the m -dimensional state of node i and u_i denote the m -dimensional input of node i . Then, the following dynamic consensus algorithm

$$\dot{q}_i = \sum_{j \in N_i} (q_j - q_i) + \sum_{j \in N_i \cup \{i\}} (u_j - q_i) \quad (30)$$

that can be equivalently expressed as

$$\dot{q} = -\hat{L}q - \hat{L}u + (I_n + \hat{A})(u - x) \quad (31)$$

with $q = \text{col}(q_1, \dots, q_n)$, $\hat{A} = A \otimes I_m$ and $\hat{L} = L \otimes I_m$ gives a low-pass consensus filter with a MIMO transfer function

$$H_{lp}(s) = [(s+1)I_n + \hat{A} + \hat{L}]^{-1}(I_n + \hat{A}) \quad (32)$$

from input u to output x .

This filter is used for fusion of the measurements that calculates \hat{y}_i by applying the algorithm to $H_i' R_i^{-1} z_i$ as the input of node i .

- **High-Pass Consensus Filter (CF_{hp}, [24], [29]):** Let p_i denote the m -dimensional state of node i and u_i denote the m -dimensional input of node i . Then, the following dynamic consensus algorithm

$$\dot{p}_i = \sum_{j \in N_i} (p_j - p_i) + \dot{u}_i \quad (33)$$

that can be equivalently expressed as

$$\dot{e} = -\hat{L}e - \hat{L}u_i \quad (34)$$

$$p = e + u \quad (35)$$

with $\hat{L} = L \otimes I_m$. This gives a high-pass consensus filter with an improper MIMO transfer function

$$H_{hp}(s) = (sI_n + \hat{L})^{-1}s \quad (36)$$

from input u to output x that becomes I_n as $s \rightarrow \infty$. This filter apparently propagates high-frequency noise and by itself is inadequate for sensor fusion.

- **Band-Pass Consensus Filter (CF_{bp}):** This distributed filter can be defined as

$$H_{bp}(s) = H_{lp}(s)H_{hp}(s) \quad (37)$$

that can be equivalently stated in the form of a dynamic consensus algorithm

$$\dot{e}_i = -\hat{L}e_i - \hat{L}u_i, \quad (38)$$

$$p_i = e_i + u_i, \quad (39)$$

$$\dot{q}_i = \sum_{j \in N_i} (q_j - q_i) + \sum_{j \in N_i \cup \{i\}} (p_j - q_i) \quad (40)$$

with a state $(e_i, q_i) \in \mathbb{R}^{2m}$, input u_i , and output q_i . This filter is used for inverse-covariance consensus that calculates \hat{S}_i column-wise for node i by applying the filter on columns of $H_i'R_i^{-1}H_i$ as the inputs of node i . The matrix version of this filter can take $H_i'R_i^{-1}H_i$ as the input.

Fig. 2 shows the architecture of each node of the sensor network for distributed Kalman filtering. Note that *consensus filtering is performed with the same frequency as Kalman filtering*. This is a unique feature that completely distinguishes our algorithm with some related work in [30], [33].

V. SIMULATION RESULTS

In this section, we use our consensus filters jointly with the update equation of the micro-Kalman filter of each node to obtain an estimate of the position of a moving object in \mathbb{R}^2 that (approximately) goes in circles. The output matrix is $H_i = I_2$ and the state of the process dynamics is 2-dimensional corresponding to the continuous-time system

$$\dot{x} = A_0x + B_0w$$

with

$$A_0 = \begin{bmatrix} 0 & -1 \\ 1 & 0 \end{bmatrix}, B_0 = I_2$$

The network has $n = 200$ sensors with a topology shown in Fig. 1. We use the following data:

$$R_i = 100(i^{\frac{1}{2}})I_2, Q = 25, P_0 = I_2, x_0 = (15, -10)'$$

with a step-time of $T = 0.02$ (sec). Figs 3 and 4 and show the estimate obtained by nodes $i = 100, 25$. Apparently, the distributed and central Kalman filters provide almost identical estimates. Of course, the difference is in *scalability* of the DKF. In Fig. 5, the consecutive snapshots of estimates of all nodes are shown. The estimates appear as a cohesive set of particles that move around the location of the object.

VI. CONCLUSIONS

The importance of distributed Kalman filtering (DKF) for sensor networks was discussed. We addressed the DKF problem by reducing it to two separate dynamic consensus problems in terms of weighted measurements and inverse-covariance matrices that can be viewed as two data fusion problems with different natures. Both data fusion problems were solved in a distributed way using consensus filters. Consensus filters are distributed algorithms that allow calculation of average-consensus of time-varying signals. We employed a low-pass consensus filter for fusion of the measurements and a band-pass consensus filter for fusion of the inverse-covariance matrices. Note that the stability properties of

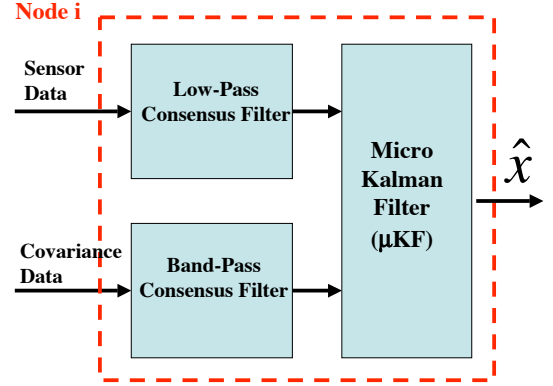

(a)

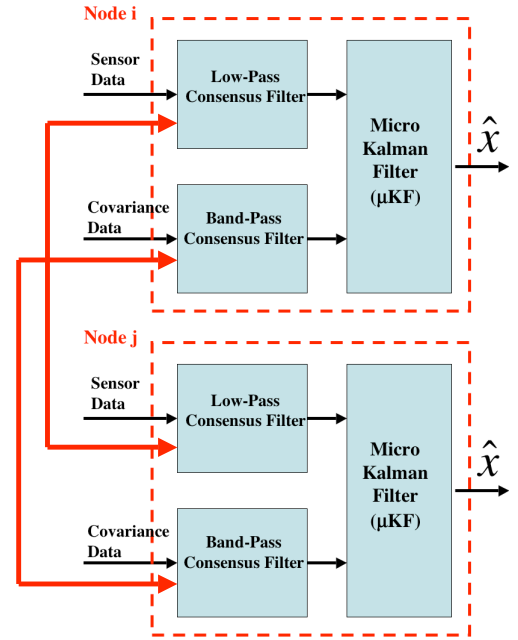

(b)

Fig. 2. Node and network architecture for distributed Kalman filtering: (a) architecture of consensus filters and μ KF of a node and (b) communication patterns between low-pass/band-pass consensus filters of neighboring nodes.

consensus filters is discussed in a companion paper [24]. We established that a central Kalman filter for sensor networks can be decomposed into n micro-Kalman filters with inputs that are provided by two consensus filters. This network of micro-Kalman filters was able to collaboratively provide an estimate of the state of the observed process. This estimate is identical to the estimate obtained by a central Kalman filter given that all nodes agree on two central sums. Consensus filters can approximate these sums and that gives an approximate distributed Kalman filtering algorithm for sensor networks. Computational and communication architecture of the algorithm was discussed. Simulation results are presented for a sensor network with 200 nodes and 1074 links.

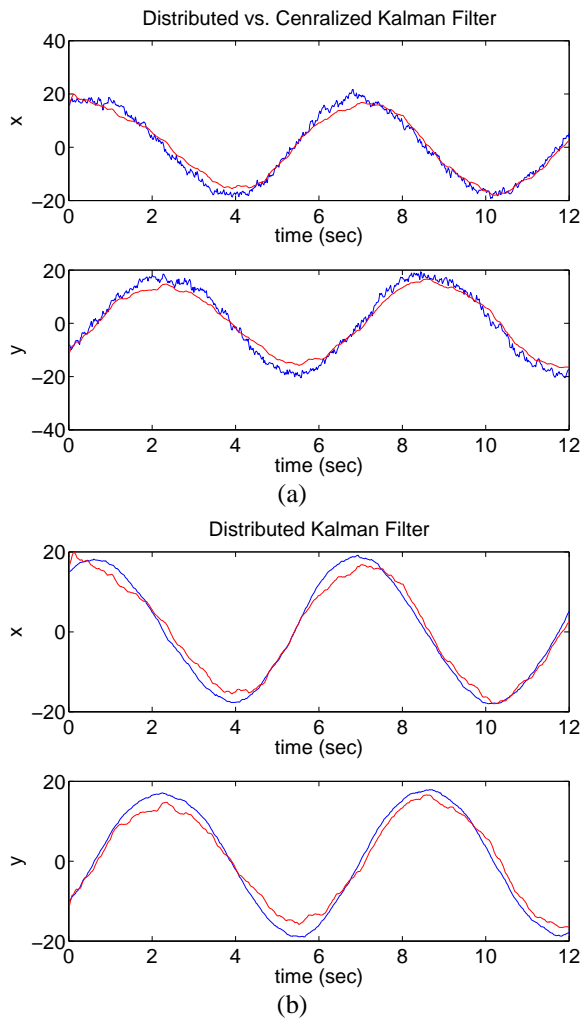

Fig. 3. Distributed position estimation for a moving object by node $i = 100$: (a) DKF vs. KF (DKF is the smooth curve in red) and (b) Distributed Kalman filter estimate (in red) vs. the actual position of the object (in blue).

ACKNOWLEDGMENTS

I would like to thank Jeff Shamma, Emilio Frazzoli, Jason Speyer, Demetri Spanos, Richard Murray, Elisa Franco, and Sonja Martinez for their valuable remarks. This research was supported in part by ARO under the grant #W911NF-04-1-0316, AFOSR MURI grant #F49620-02-1-0325, and NSF ITR grant #0325716. This work was done while the author was a visiting scientist at the University of California, Los Angeles.

REFERENCES

- [1] I. Akyildiz, W. Su, Y. Sankarasubramniam, and E. Cayirci. A survey on sensor networks. *IEEE Communications Magazine*, pages 102–114, August 2002.
- [2] B. D. O. Anderson and J. B. Moore. *Optimal Filtering*. Prentice-Hall, Englewood Cliffs, NJ., 1979.
- [3] J.-Y. Chen, G. Pandurangan, and D. Xu. Robust computation of aggregates in wireless sensor networks: distributed randomized algorithms and analysis. *Fourth International Symposium on Information Processing in Sensor Networks*, pages 348–355, April 2005.

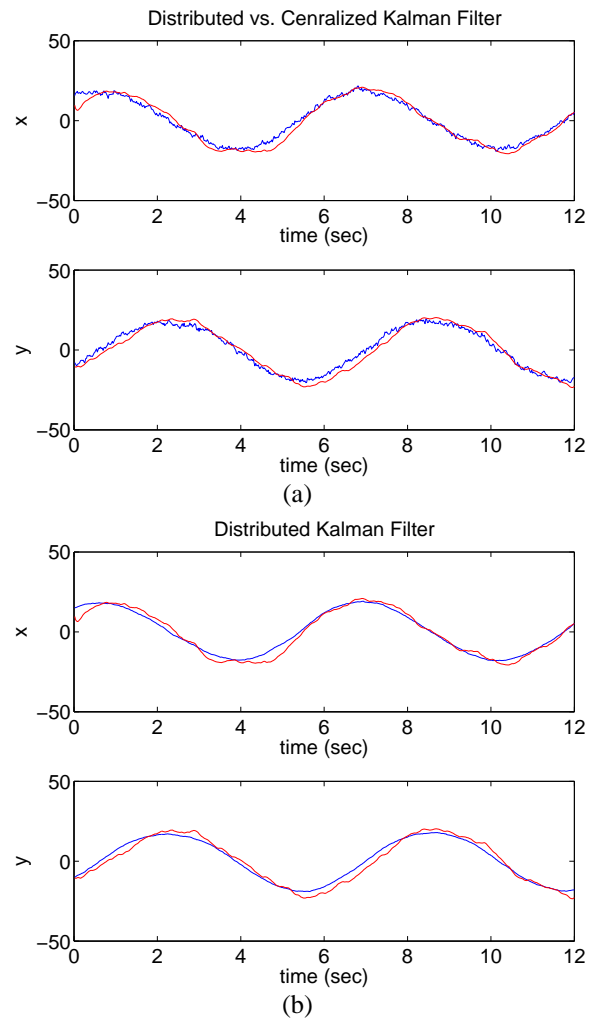

Fig. 4. Distributed position estimation for a moving object by node $i = 25$: (a) DKF vs. KF (DKF is the smooth curve in red) and (b) Distributed Kalman filter estimate (in red) vs. the actual position of the object (in blue).

- [4] M. Chu, H. Haussecker, and F. Zhao. Scalable information-derived sensor querying and routing for ad hoc heterogeneous sensor networks. *International Journal of High-Performance Computing Applications*, 16(3):293–313, 2002.
- [5] J. Cortes, S. Martinez, T. Karatas, and F. Bullo. Coverage control for mobile sensing networks. *The IEEE Trans. on Robotics and Automation*, 20(2):243–255, April 2004.
- [6] H. Durrant-Whyte. Data fusion in sensor networks. *Fourth International Symposium on Information Processing in Sensor Networks*, April 2005.
- [7] D. Estrin, R. Govindan, J. Heidemann, and S. Kumar. Next century challenges: scalable coordination in sensor networks. *Proc. of Mobile Computing and Networking*, pages 263–270, 1999.
- [8] E. Franco, R. Olfati-Saber, T. Parisini, and M. M. Polycarpou. Distributed Fault Diagnosis using Sensor Networks and Consensus-based Filters. *American Control Conference*, 2006 (submitted).
- [9] M. P. J. Fromherz, L. S. Crawford, C. Guettier, and Y. Shang. Distributed Adaptive Constrained Optimization for Smart Matter Systems. *AAAI Spring Symposium on Intelligent Distributed and Embedded Systems*, March 2002.
- [10] C. Godsil and G. Royle. *Algebraic Graph Theory*, volume 207 of *Graduate Texts in Mathematics*. Springer, 2001.
- [11] S. Grime and H. Durrant-Whyte. Data fusion in decentralized sensor networks. *J. Control Engineering Practice*, 2, 1994.
- [12] Y. Hatano and M. Mesbahi. Agreement over random networks. *IEEE Conf. on Decision and Control*, 2004.
- [13] W. R. Heinzelman, J. Kulik, and H. Balakrishnan. Adaptive protocols

- for information dissemination in wireless sensor networks. *Proc. of Mobile Computing and Networking*, pages 174–185, 1999.
- [14] N. A. Lynch. *Distributed Algorithms*. Morgan Kaufmann Publishers, Inc., 1997.
- [15] S. Martinez and F. Bullo. Optimal sensor placement and motion coordination for target tracking. *Automatica (submitted)*, 2004.
- [16] S. Meguerdichian, F. Koushanfar, M. Potkonjak, and M. B. Srivastava. Coverage problems in wireless ad-hoc sensor networks. *Proceedings of IEEE Infocom*, 3:1380–1387, April 2001.
- [17] M. Mesbahi. On state-dependent dynamic graphs and their controllability properties. *IEEE Trans. on Automatic Control*, 50(3):387–392, 2005.
- [18] L. Moreau. Stability of multiagent systems with time-dependent communication links. *IEEE Trans. on Automatic Control*, 50(2):169–182, 2005.
- [19] P. Ogren, E. Fiorelli, and N. E. Leonard. Cooperative control of mobile sensor networks: adaptive gradient climbing in a distributed environment. *IEEE Trans. on Automatic Control*, 49(8):1292–1302, 2004.
- [20] R. Olfati-Saber. Flocking for multi-agent dynamic systems: theory and algorithms. *IEEE Trans. on Automatic Control (to appear)*, 2005.
- [21] R. Olfati-Saber. Ultrafast consensus in small-world networks. *Proceedings of American Control Conference*, June 2005.
- [22] R. Olfati-Saber, E. Franco, E. Frazzoli, and J. S. Shamma. Belief consensus and distributed hypothesis testing in sensor networks. *Workshop on Network Embedded Sensing and Control, Notre Dame University*, Oct 2005 (submitted).
- [23] R. Olfati-Saber and R. M. Murray. Consensus problems in networks of agents with switching topology and time-delays. *IEEE Trans. on Automatic Control*, 49(9):1520–1533, Sep. 2004.
- [24] R. Olfati-Saber and J. S. Shamma. Consensus filters for sensor networks and distributed sensor fusion. *Proceedings of the 44th Conference on Decision and Control*, 2005.
- [25] B. S. Y. Rao, H. F. Durrant-Whyte, and J. A. Sheen. A fully decentralized multi-sensor system for tracking and surveillance. *Int. Journal of Robotics Research*, 12(1):20–44, Feb 1993.
- [26] W. Ren and R. W. Beard. Consensus seeking in multiagent systems under dynamically changing interaction topologies. *IEEE Trans. on Automatic Control*, 50(5):655–661, 2005.
- [27] R. O. Saber and R. M. Murray. Consensus protocols for networks of dynamic agents. *Proc. of the American Control Conference*, 2:951–956, June 2003.
- [28] Y. Sheng, X. Hu and P. Ramanathan. Distributed particle filter with GMM approximation for multiple targets localization and tracking in wireless sensor networks. *Fourth International Symposium on Information Processing in Sensor Networks*, April 2005.
- [29] D. Spanos, R. Olfati-Saber, and R. M. Murray. Consensus Tracking in Mobile Networks. *The 16th IFAC World Congress, Prague, Czech*, 2005.
- [30] D. P. Spanos, R. Olfati-Saber, and R. M. Murray. Approximate distributed Kalman filtering in sensor networks with quantifiable performance. *Fourth International Symposium on Information Processing in Sensor Networks*, pages 133–139, April 2005.
- [31] J. L. Speyer. Computation and transmission requirements for a decentralized linear-quadratic-gaussian control problem. *IEEE Trans. on Automatic Control*, 24(2):266–269, Feb 1979.
- [32] L. Xiao and S. Boyd. Fast linear iterations for distributed averaging. *Systems & Control Letters*, 52:65–78, 2004.
- [33] L. Xiao, S. Boyd, and S. Lall. A scheme for asynchronous distributed sensor fusion based on average consensus. *Fourth International Symposium on Information Processing in Sensor Networks*, April 2005.
- [34] Y. M. Zhu, Z. S. You, J. Zhou, K.-S. Zhang, and X. R. Li. The optimality for the distributed Kalman filtering fusion with feedback. *Automatica*, 37:1489–1493, 2001.

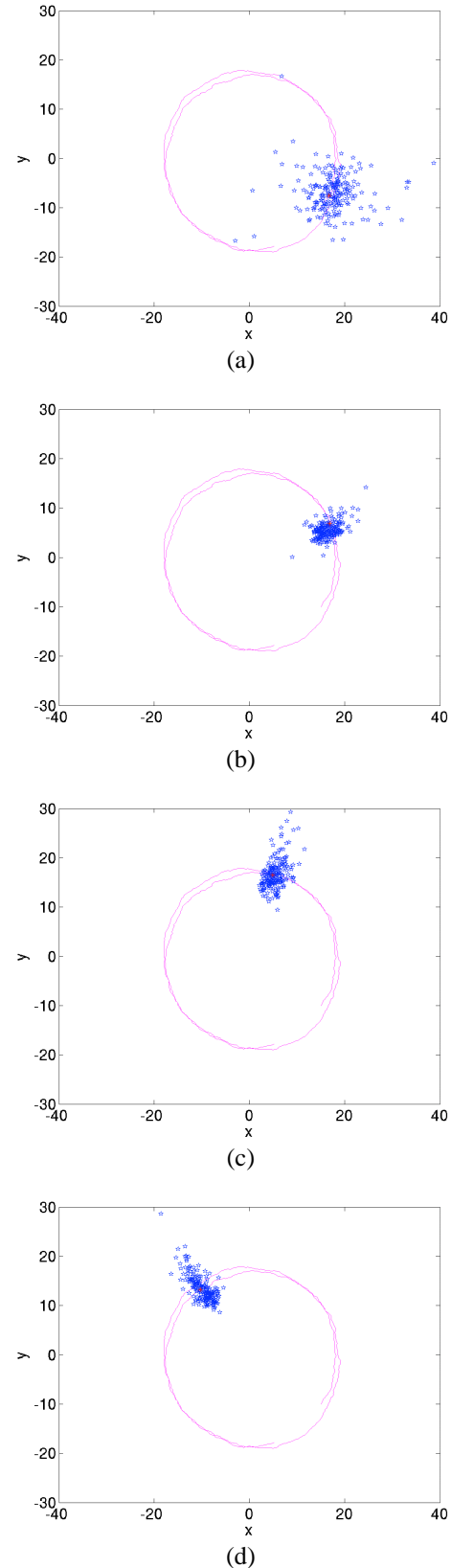

Fig. 5. Snapshots of the estimates of all nodes regarding the position of a moving object (a red dot).